

# SOM-7562 B1

Intel® Atom™ Processor N455  
COM-Express Mini Module

NEW



TAIWAN  
EXCELLENCE 2012

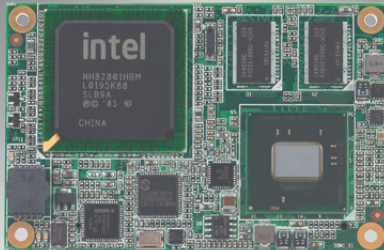

## Features

- Embedded Intel® Atom™ Processor N455 1.66 GHz + ICH8M
- Intel Gen 3.5 DX9, MPEG2 hardware decoder, supports 18-bit LVDS, VGA
- Supports 1 GB on-board memory and 1/2 GB on-board Flash
- Supports 5 PCIe x1, LPC, 3 SATAII, 8 USB 2.0, GbE
- Supports SUSIAccess and Embedded Software APIs

### Software APIs:



Watchdog



FC



SMBus



H/W Monitor



GPIO



Backlight On/Off

### Utilities:



BIOS flash



Monitoring



Embedded Security ID

## Specifications

Form Factor		COM-Express Mini Module, Type I Pin-out
Processor System	CPU	Intel Atom Processor N455 1.66 GHz
	L2 Cache	512 KB
	System Chipset	ICH8M
	BIOS	AMI 16 Mbit Flash BIOS
Memory	Technology	DDR3 667 MHz memory only
	Max. Capacity	Onboard 1GB
	Socket	-
Flash	Capacity	1 GB/ 2 GB Flash onboard
Display	Chipset	Embedded Gen3.5+ GFX Core
	Graphics Engine	Intel Gen 3.5 DX9, MPEG2 hardware decoder
	LVDS	18-bit single channel LVDS
	VGA	Supports max. 1400 x 1050 @ 60 Hz
	DVI	-
	TV Out	-
	SDVO	-
Dual Display		CRT + LVDS
Ethernet	Chipset	Intel 82567V Gigabit Ethernet
	Speed	10/100/1000 Mbps
WatchDog Timer		256 level timer interval, from 0 to 255 sec or min setup by software, jumperless selection, generates system reset
Expansion		LPC, 5 PCIe x1 (1 PCIe x4 or 1 PCIe x2 option)
I/O	PATA	-
	SATA	3 x SATAII (300 MB/s)
	USB	8 x USB 2.0
	Audio	High definition audio interface
	GPIO	8-bit GPIO
Power	Power Type	ATX, AT
	Power Supply Voltage	12 V (5 VSB needed for ATX power mode), wide range voltage supported on a per project basis
	Power Consumption (Typical)	+12 V @ 0.68 A
	Power Consumption (Max. test in HCT)	+12 V @ 0.86 A
Environment	Operating Temperature	0 ~ 60° C (32 ~ 140° F)
	Operating Humidity	0% ~ 90% relative humidity, non-condensing
Mechanical	Dimensions	84 x 55 mm (3.3" x 2.17")

## Block Diagram

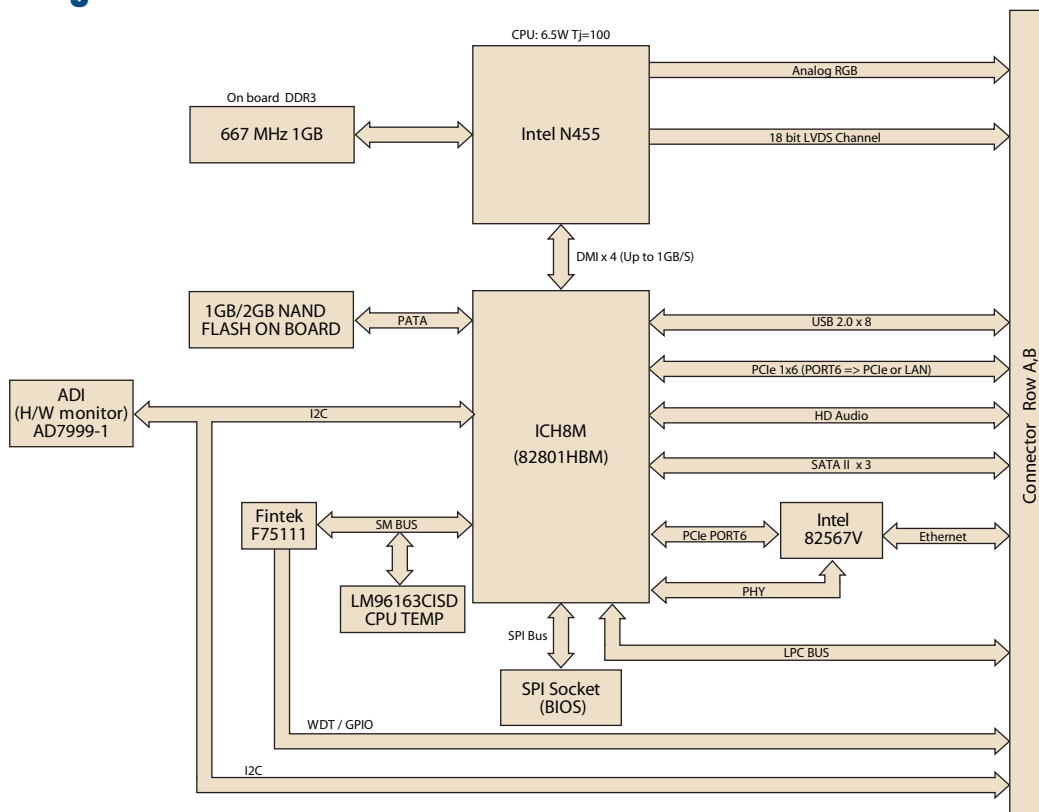

## Ordering Information

Part No.	CPU	L2 Cache	Chipset	Onboard Memory	Onboard Flash	LVDS	VGA	Giga LAN	HD Audio	PCIe x 4	PCIe x 1	USB 2.0	SATA II	LPC	SMBUS	Wide range Power	ATX Power	AT Power	Thermal Solution	Operating Temp.
SOM-7562F1-S6B1E	Intel Atom N455	512 KB	ICH8M	1 GB	1 GB	18-bit	Yes	1	Yes	Option	5	8	3	1	1	+5V--+14V	Yes	Yes	Passive	0 - 60 °C
SOM-7562F2-S6B1E	Intel Atom N455	512 KB	ICH8M	1 GB	2 GB	18-bit	Yes	1	Yes	Option	5	8	3	1	1	+5V--+14V	Yes	Yes	Passive	0 - 60 °C
SOM-7562SZ-S6B1E	Intel Atom N455	512 KB	ICH8M	1 GB	1 GB	18-bit	Yes	1	Yes	Option	5	8	3	1	1	+5V--+14V	Yes	Yes	Passive	-20 - 80 °C
SOM-7562SZ2-S6B1E	Intel Atom N455	512 KB	ICH8M	1 GB	1 GB	18-bit	Yes	1	Yes	Option	5	8	3	1	1	+5V--+14V	Yes	Yes	Passive	-40 - 85 °C
SOM-7562UZ-S6B1E	Intel Atom N455	512 KB	ICH8M	1 GB	2 GB	18-bit	Yes	1	Yes	Option	5	8	3	1	1	+5V--+14V	Yes	Yes	Passive	-20 - 80 °C
SOM-7562UZ2-S6B1E	Intel Atom N455	512 KB	ICH8M	1 GB	2 GB	18-bit	Yes	1	Yes	Option	5	8	3	1	1	+5V--+14V	Yes	Yes	Passive	-40 - 85 °C

Note: Passive = fanless; Active = with fan

## Development Board

Part No.	Description
SOM-DB5700G-U0A2E	Development Board for COM-Ultra Modules with GLAN

## Embedded OS

OS	Part No.	Description
Win XPE 2008	2070009031	XPE WES2009 Lu- Pier V4.0 MUI24

## Packing List

Part No.	Description	Quantity
	SOM-7562 CPU Module	1
	Utility CD	1
	Heatspreader	1